

GAME BOY ADVANCE

AGB-BZ5E-USA



FINAL FANTASY V[®]
ADVANCE

INSTRUCTION BOOKLET

<http://www.replacementdocs.com>

SQUARE ENIX™

The official seal is your assurance that this product is licensed or manufactured by Nintendo. Always look for this seal when buying video game systems, accessories, games and related products.



Nintendo does not license the sale or use of products without the Official Nintendo Seal.

NEED HELP PLAYING A GAME?

Nintendo's game pages, at www.nintendo.com/games, feature walkthroughs, frequently-asked questions, and codes for many of our games. If your answer isn't there, check out our forums where you can exchange tips with other gamers online.

For more information about our forums, visit www.nintendo.com/community.

If you prefer to use your phone, recorded tips for some of our hottest games are available on our Power Line at (425) 885-7529. This may be a long-distance call, so please ask permission from whoever pays the phone bill.



© 1992, 2006 SQUARE ENIX CO., LTD. ILLUSTRATION © 1992, 2006 Yoshitaka Amano. FINAL FANTASY, SQUARE ENIX, and the SQUARE ENIX logo are trademarks or registered trademarks of SQUARE ENIX CO., LTD. TM, ® and Game Boy Advance are trademarks of Nintendo. © 2006 Nintendo. All rights reserved.

PROLOGUE

Fire, Water, Wind, and Earth. Peace and prosperity reign thanks to the power of these four crystals.

However...that power is nearing its limit. Not far off is the day when the wind slows, the water stills, and the earth trembles and quakes...

Yet everyone remains blissfully unaware, and the grave secret hidden within the crystals remains untold...



CONTENTS

Characters	6
Basic Controls.....	8
Getting Started.....	10
The Adventure Begins.....	12
Around the World	13
Main Menu	16
Menu Commands.....	18
Battle View.....	24
Battle Commands	26
Jobs and Abilities	30
Job List.....	34
Spell List	42

CHARACTERS

An introduction to the characters appearing in FINAL FANTASY V Advance.



BARTZ KLAUSER

An orphaned young man who travels the world with Boko, his chocobo companion. Though sometimes blunt, Bartz possesses a sense of justice that won't allow him to abandon those in need. Having studied with his late father, Bartz's skills with a blade are nothing to laugh at.



LENNA CHARLOTTE TYCOON

The kind and gentle-hearted princess of Tycoon. She searches for her father, last seen on his way to the Wind Shrine. Unable to save her sick mother's life, Lenna now sometimes acts recklessly to protect those around her.



GALUF DOE

An old man with a serious case of amnesia, Galuf's past is a mystery. However, his seasoned swordsmanship and lordly presence hint at a history as a proud warrior. Upbeat and outspoken, Galuf always has words of encouragement for the rest of the group.

FARIS SCHERWIZ

The captain of an unruly yet loyal band of pirates. A fierce and focused fighter, once Faris' sights are set on something, the pirate's soul will stop at nothing to have it. Despite being young, Faris easily commands the respect of others.



BASIC CONTROLS

Below are basic controls for
FINAL FANTASY V.

L BUTTON

- ◆ Switch pages – Available in menus where the L and R Buttons appear at the edges of the screen
- ◆ Switch characters with the L and R Buttons while in menus



+ CONTROL PAD

- ◆ Move character
- ◆ Move cursor



START

- ◆ Open main menu
- ◆ Pause/Resume battle

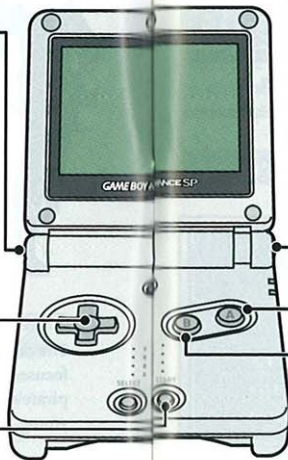

R BUTTON

- ◆ Switch pages – Available in menus where the L and R Buttons appear at the edges of the screen
- ◆ Display the world map

A BUTTON

- ◆ Confirm
- ◆ Talk
- ◆ Examine
- ◆ Board/Disembark transportation, such as a chocobo

The A Button is the main action button in the game.



B BUTTON

- ◆ Cancel
- ◆ Press and hold to move faster in towns and dungeons

To return to the title screen, press and hold the A Button + B Button + START + SELECT.

Press and hold the L Button and R Button during battle to flee.

GETTING STARTED

How to start a game and save your progress.

Starting the Game

After an introductory scene, the title screen will appear. Select New Game to play from the beginning, or continue a quest by selecting Load Game. Selecting Extra allows you to check the Bestiary or use the music player.



Starting a New Quest

After a few minutes of play, you will be prompted to enter a name for your main character.

Name Entry Controls

+Control Pad – Move cursor

A Button – Enter letter

B Button – Backspace

L Button / R Button – Toggle upper or lowercase letters

START – Confirm name and exit menu

SELECT – Enter the default name "Bartz"



Continuing a Previously Saved Game

Select Load Game and then select the save file.

Saving a Game

Select Save from the main menu (p. 16). You can save either in the field (p. 13) or at certain save points within dungeons and similar areas. You are allowed up to four saved games.

Save Point



Quicksave

Select Quicksave from the main menu to temporarily save anywhere in the game. To continue, select Continue from the title screen. Remember that when a game is resumed or play is begun with New Game or Load Game, the Quicksave data is discarded.



THE ADVENTURE BEGINS

Your FINAL FANTASY V Advance adventure plays out in three different types of views:



FIELD/ DUNGEON/TOWN

Travel to many places and advance the story from this view. The bulk of the game will be spent here.

Barth	Freelancer	Job	Ability
LV 5	HP 92/92	Item	24
	SP 24/24	Magic	24
Lenne	Freelancer	Equip	
LV 5	HP 89/89	Status	
	SP 26/26	Config	
Gau	Freelancer	Overdrive	
LV 5	HP 93/93	Time	
	SP 14/14	World Map	
Faris	Freelancer	Play time	0:43
LV 5	HP 87/87	GM	1561
	SP 25/25		

MENU [PP. 16-23]

Press START while on the field to open the menu. Here you can check and examine your inventory, adjust equipment or jobs, or customize other settings.



BATTLE [PP. 24-29]

When you encounter monsters on the field or during events, the action will switch to this view. Here you can choose different battle commands in order to fight.

AROUND THE WORLD

The field view is where most of your adventure occurs. Here characters do substantial work — everything from trekking across the world to searching out information in towns and villages. They can also shop here, or rest at an inn.

The Field

Your characters act differently in the field than in dungeons or towns. After you get the world map, you can check your location in the world by pressing the R Button from anywhere in the field.



The Field



Town/Dungeon

All Sorts of Transportation

Here is a brief introduction to some types of transportation you will encounter on your quest. In general, you can board or disembark with the A Button.



CHOCOBOS

Chocobos run over land much faster than you can travel on foot.



AIRSHIPS

With an airship, the skies are yours. Landing on fields or in deep water is no problem.



BOATS

Sail to faraway lands with a good ship.

Talking/Examining

Press the A Button to speak to other characters, examine boxes or chests for items, flip switches, or perform any number of other actions. You never know just who or what will yield important information, so you'll use this button a lot!



Recovery Springs

Springs with magical properties are scattered around dungeons and towns throughout the world. Drink from a recovery spring to fully restore HP and MP (p. 17), and cure status ailments (p. 29).



The Greenhorn's Club

The Greenhorn's Club is full of great advice for novice adventurers. If you have the chance to visit this special place, definitely take it.



Towns

They say that money makes the world go 'round, and there are plenty of places to spend your hard-earned gil. Resting at an inn will restore HP and MP, as well as cure all status ailments except zombification. Shopkeepers around the world are always willing to sell you the finest new goods, and even buy back old or unneeded equipment.



Shopping

Speak to a shopkeeper to open up the shop menu. Choose to buy or sell, and you will be presented with a list of items the shop sells or your own inventory. Select the item you want to purchase (or sell) with the + Control Pad, and confirm with the A Button.

Shop Menu

Purchase items by selecting Buy, or sell inventory with Sell.

Remaining Money (Gil)

Number of Items Held and Items Currently Equipped

Equipment Comparison

- Better than currently equipped
- No stat difference
- Worse than currently equipped

Anything caught your eye?		Armor	
Buy	Sell	Buy	Sell
Mythral Shield	590	16240	0
Mythral Helm	550	Gil	Equip
Plumed Hat	350		2
Mythral Armor	700		

Light cap seen from afar.

MAIN MENU

Perform various actions such as checking character status, saving your game, and more from the main menu.

Press START while in the field to open the menu. You can check the party's status, use items or magic, select equipment, or change other settings.

Navigating the Menu

The character placed at the top of the menu is who appears as you move around the world. As the game progresses, you will be able to select Jobs and Abilities as well.

The screenshot shows the Main Menu with the following elements and callouts:

- Party Members:** A list of party members with their stats.

Bartz	Knight	LV 2-	6 / 50
	HP	172 / 197	
	MP	26 / 30	
Lenna	White Mage	LV 2-	16 / 30
	HP	100 / 142	
	MP	53 / 61	
Galuf	Monk	LV 1-	19 / 30
	HP	176 / 215	
	MP	20 / 23	
Faris	Black Mage	LV 2-	15 / 30
	HP	122 / 122	
	MP	51 / 55	
- Jobs and Abilities:** A menu with options: Job Ability, Item, Magic, Equip, Status, Config, Quicksave, Save.
- Menu Commands (pp. 18-23):** A callout pointing to the Jobs and Abilities menu.
- Current Location:** Ship Graveyard.
- Time Played:** 1 : 11.
- Money (Gil):** 4259.

Party Members

Check characters' levels, HP, MP, current job, and status ailments.

The screenshot shows the Party Members menu for Bartz with the following callouts:

- Job Information:** Current job and job level, current ABP/ABP required to level up (p. 32).
- HP/Max HP:** HP measures a character's life force. When that character is hurt in battle, HP will decrease.
- MP/Max MP:** MP is a measure of a character's magical reserves. As spells are cast, MP will decrease.
- Level:** In fighting battles, the party will gain experience. Once this combined experience rises to a certain level, a party member will become stronger and more able.

Bartz	Knight	LV 2-	6 / 50
	HP	172 / 197	
	MP	26 / 30	

Changing Formation

Press +Control Pad Left on the main menu to move the cursor over party members. Now you can change the party's order, or change the row of specific characters.

Select the character you want to move and press the A Button. Choose another character and press the A Button to switch the characters' positions. Selecting the character you want to move and then pressing the A Button twice will change them from the front row (p. 28) to the back, and vice versa.

The screenshot shows the Party Members menu with callouts for the Front Row and Back Row:

- Front Row:** Points to Bartz (Knight, LV 2-, 6 / 50, HP 172 / 197, MP 26 / 30).
- Back Row:** Points to Lenna (White Mage, LV 2-, 16 / 30, HP 100 / 142, MP 53 / 61).

Bartz	Knight	LV 2-	6 / 50
	HP	172 / 197	
	MP	26 / 30	
Lenna	White Mage	LV 2-	16 / 30
	HP	100 / 142	
	MP	53 / 61	
Galuf	Monk	LV 1-	19 / 30
	HP	176 / 215	
	MP	20 / 23	
Faris	Black Mage	LV 2-	15 / 30
	HP	122 / 122	
	MP	51 / 55	

MENU COMMANDS

An explanation of commands displayed on the main menu.

Item

Select Item to open the inventory, where you can check the numbers and descriptions of items in your possession, as well as use them. You can scroll the inventory list with the L and R Buttons.

Item Sub-Commands Press the B Button to move the cursor to the item sub-command list.

Use	Sort	Rare	Item
Potion	6	Maiden's Kiss	1
Phoenix Down	6	Ether	4
Antidote	2	Gold Needle	2
Hi-Potion	2	Tent	2
Cottage	2	Elkar	6
Speed Shake	1	Turtle Shell	4
Shuriken	2	Thief's Gloves	1
Dagger	2	Arthur's	1
Whip	1	Mythral Knife	1

Item List Usable items are displayed in white.

Item Sub-Commands

Use	Select items to use them.
Sort	Automatically arrange items by type.
Rare	Special quest items or personal items are kept here.

Using Items

Move the cursor to the item you want to use, then press the A Button twice to use it. Depending on the item, you may need to select a target.

Bartz	Knight	LV 2-	6/	50	Use on whom?
		HP	122/	197	Potion
		MP	26/	30	Hold
					5
Lenna	White Mage	LV 2-	16/	30	Restores HP.
		HP	100/	142	
		MP	53/	61	
Gain	Monk	LV 1-	19/	30	
		HP	176/	215	
		MP	20/	23	
Faris	Black Mage	LV 2-	15/	30	Select
		HP	122/	122	Done
		MP	51/	55	

Arranging the Inventory

Select an item with the A Button, then move the cursor to the desired position and press the A Button again. This will switch the positions of the two selected items.

Use	Sort	Rare	Item
Potion	6	Maiden's Kiss	1
Phoenix Down	6	Ether	4
Antidote	2	Gold Needle	2
Hi-Potion	2	Tent	2
Cottage	2	Elkar	6
Speed Shake	1	Turtle Shell	4
Shuriken	2	Thief's Gloves	1
Dagger	2	Arthur's	1
Whip	1	Mythral Knife	1

Restores HP.

Equippable Gear

There are many types of gear that can be equipped by party members. In the inventory, the different types of gear are indicated by different icons.

WEAPONS



ARMOR

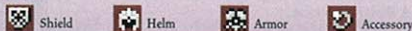

Magic

With this command, you can check the effects of spells you have already learned, or cast spells on the party. Select the type of magic you want to check, then choose the spell you want to use from the spell list. In addition to meeting certain conditions to become a mage, you must obtain spells from magic shops, or find them hidden around the world.

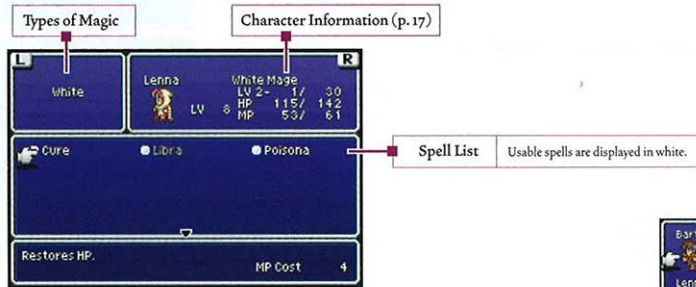

Casting on the Whole Party

Spells can be cast on the entire party. When selecting a target for the spell, press +Control Pad Right to target everyone, then press the A Button to cast.

Equip

Use this screen to equip weapons or armor. The gear a character can equip will change depending on the job and abilities they have set. Except for shields, pieces of armor may or may not be equippable depending on the character's job.

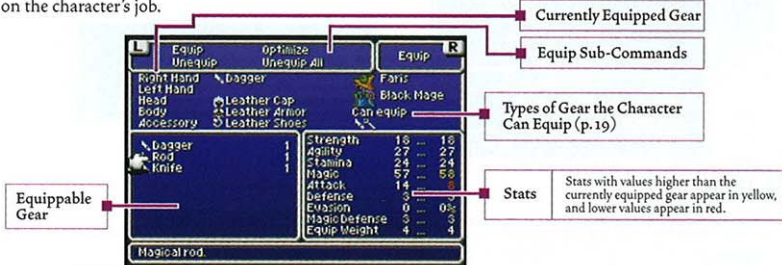

Equip Sub-Commands

- | | |
|-------------|--|
| Equip | Select the body part you would like to equip, then select an item. Gear that cannot be equipped will not be displayed. |
| Optimize | Automatically equips the weapons and armor that provide the highest attack and defense stats. |
| Unequip | Select the body part you would like to remove equipment from, then press the A Button. |
| Unequip All | Removes all of the character's equipment. |

Status

Check characters' strength, levels, experience points, and more.

Press the A Button to view more information on a character.



Stats

Stats change depending on the character's level, job, and currently equipped items.

Strength	Influences the effectiveness of physical attacks.
Agility	Speed at which characters take action in battle.
Stamina	Influences the amount of damage taken from physical attacks.
Magic	Level of magical strength; influences the effectiveness of spells.
Attack	Influences the damage by physical attacks.
Defense	Defensive strength against physical attacks.
Evasion	Probability of evading an attack.
Magic Defense	Defensive strength against magical attacks.
Weight	Equipment weight; influences the character's agility.

Config

The Config menu lets you change many system settings, such as battle mode, message speed, or window color.

Quicksave

Choose the Quicksave option (p. 11) to temporarily suspend your game.

Save

Save game data. This can only be done in the field (p. 13) or at save points (p. 11).

BATTLE VIEW

When attacked by enemies in dungeons or in the field, you will be taken to this screen to fight. Choose from different commands to fight your way to victory.

Battle

After entering battle, each character has a gauge that rises according to their agility stats. Enter commands in the order each character's gauge is filled. Enemies can continue to attack while you select commands, spells, or items.

You can stop the passage of time during command selection by changing the Battle Mode setting in the Config menu to Wait.



Allies' HP and ATB Gauge

Gauges will fill faster for characters with higher agility (p. 22).

Battle Commands (pp. 26-28)

Enemy Name

Ending a Battle

Battles end when all enemies have been defeated, all enemies have fled, or the party has fled. Winning battles can earn the party money (gil), experience points, ability points (p. 30), or even items.

Treasure

Sometimes defeated enemies drop treasure. Choose to Take All treasures or Exit the menu.

Game Over

The game ends when the entire party is KO'd, petrified, or zombified (p. 29). You will have to restart from the last place you saved, so be sure to save often.



BATTLE COMMANDS

Attack

Attack the enemy with the currently equipped weapon. If nothing is equipped, a barehanded attack will be performed. You can select a target for your attack.



Specialized Commands

Different jobs (p. 30) and abilities (p. 32) will cause different commands to become available (for example, Summon, Jump, or Steal).



Selecting All

Some specialized commands, such as Magic, can be performed on all allies or all enemies. When choosing a target, continue to press the +Control Pad until all enemies or all allies are selected.



A description of basic commands used in battle.

Item

Use items or change equipment. Select the item or weapon to use, then select the target.



Changing Weapons During Battle

Select Item, and the inventory will be displayed. Press +Control Pad Up to display the equipment area, then select the gear you would like to remove with the A Button. Select the weapon you would like to equip, and confirm with the A Button.



Special Encounters

Some enemy encounters may feature different positioning, such as preemptive strikes or back attacks. In a preemptive strike, the party's ATB gauges (p. 24) will be filled from the start. In a back attack, the party will be caught from behind, meaning the back row will be in front (p. 28), and vice versa.



Defend

Press +Control Pad Right when selecting a command, and the Defend option will appear. Press the A Button, and characters will brace themselves against physical attacks.

Row

Press +Control Pad Left when selecting a command, and the Row option will appear. Pressing the A Button will switch that character's row.

Front Row and Back Row

Characters in the front row will deliver stronger blows, but take more damage. Characters in the back row will take less damage, but inflict weaker blows.

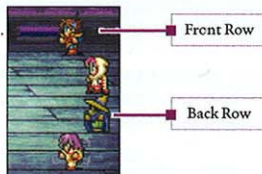

Fleeing

Press and hold the L and R Buttons in battle to run away. However, you cannot run from certain battles, so look out!



Status Ailments

When hit by enemies' special attacks, you may suffer one or more of the status ailments listed below. They can be cured with items or magic, and some fade after battle.

Do not subside after battle



KO
HP falls to zero; cannot act until restored.



PETRIFY
Turned to stone, unable to move.



TOAD
Attack and defense decrease; can't cast any spell but "Toad."



MINI
Attack and defense decrease.



POISON
HP gradually falls.



DARKNESS
Vision worsens; physical attacks more likely to miss.



ZOMBIE
Become undead; attack allies.

Subside after battle



AGING
Stats fall little by little.



SILENCE
Unable to use magic other than Blue Magic.



SLEEP
Fall asleep; cannot act until awakened.



PARALYZE
Cannot move; unable to act.



CONFUSE
Commands not accepted; may attack allies or heal enemies.



BERSERK
Commands not accepted; repeatedly perform physical attacks.

JOBS & ABILITIES

An explanation of jobs, abilities, and the job system.

Why Get a Job?

Jobs describe the type of warrior a particular character is. Depending on the job a character has set, they gain different commands and abilities. For more on the different jobs and their special abilities, please see pages 34-41.

ABP and Job Levels

When a job other than freelancer is set, ability points (ABP) will be gained by winning battles. Once enough ABP have been gained, the character's job level will increase, earning that character new abilities (p. 32).



Job Commands and Specialties

Each job has a specialized command (p. 26) that can be used in battle, as well as special abilities inherent to that job. These commands and inherent abilities are learned as jobs level up, and then can be used even while a different job is set. Not all inherent abilities can be learned.

The Job Screen

Choose Job from the main menu (p. 16) and select a character to open the Job screen.

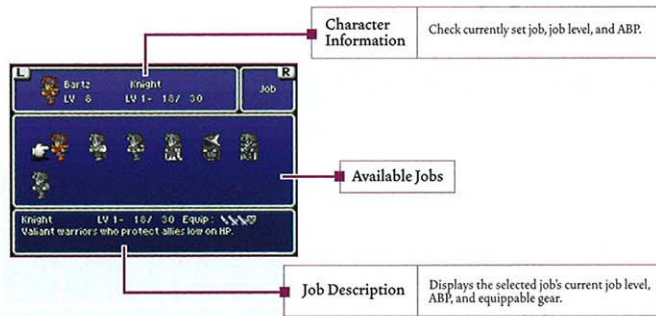

Changing Jobs

Characters' jobs are changed on the Job screen. Choose a job from the list. The gear characters can equip changes depending on their job and abilities, so once a new job is selected, you will automatically be taken to the Ability screen (p. 32), and then to the Equip screen (p. 21).

What's an Ability?

Each job has special abilities inherent to it. As a job's level increases, characters begin learning those abilities, and can use abilities separate from their respective jobs. Once an ability is learned, it can be set onto a job through the Ability screen.

Some jobs have more learnable abilities than others.

The Ability Screen

Choose Ability from the main menu, and select a character. You can then set abilities for that character.

Character Information

Job Command The specialized command available in battle due to the currently selected job.

Current Ability Set the ability you want the character to have.

Learned Abilities A list of the abilities the character has learned. Abilities beginning with an exclamation point (!) are commands used in battle.

Job Command	! Black
Ability	! White
End	

Setting Abilities

After selecting an ability from the list, move the cursor to End.



Ready, Willing, but Unable...?

While all abilities are helpful, some combinations of jobs and abilities or abilities and commands may cancel each other out, or even be harmful to the character. Pay close attention to the effects of abilities when setting them!

You can set the ability "Berserk" on a white mage, but...



...since they're berserk in battle, they won't be able to use magic at all!



You can set the ability "Equip Shields" on a mystic knight, but...

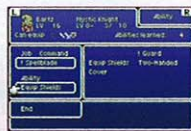



...mystic knights can already equip shields, so there's no point!





JOB LIST

A brief introduction to the different jobs and their inherent abilities. Though you begin the game as a freelancer, more jobs will become available to you as your quest progresses.*

FREELANCER 	Jacks-of-all-trades, freelancers are what all characters start out as. They have no particular specialization, but can equip any type of weapon or armor.	
	Freelancers do not gain job levels.	
KNIGHT 	Skilled with a sword, knights maintain a balance between attacking and protecting allies.	
	Job Command: Guard	Specialty: Cover
1 Cover	Protect allies with low HP.	
2 Guard	Absorb the damage of a physical attack.	
3 Two-Handed	Wield a weapon with two hands to double attack power (shields cannot be equipped).	

* This guide only includes abilities learned by job level 3. For further abilities, you'll have to play the game and find out for yourself!

MONK 	Masters of unarmed combat, monks possess an awesome destructive force.	
	Job Command: Kick	Specialties: Counter, Barehanded
1 Focus	Focus energies for one round to deliver a blow that is twice as powerful.	
2 Barehanded	When unarmed, the character's strength becomes equal to a monk's.	
3 Chakra	Healing energies recover HP and cleanse the body of darkness and poison.	
THIEF 	Swift and agile, thieves learn many abilities that are useful in your quest.	
	Job Command: Steal	Specialties: Find Passages, Artful Dodger, Sprint
1 Find Passages	Detect hidden passageways.	
2 Flee	Quickly escape from battle. You may be unable to escape from some enemies.	
3 Sprint	Hold down the B Button and the +Control Pad to move faster in towns and dungeons.	
DRAGOON 	Known for their high jumps and attacks from above, dragoons suffer no penalties when attacking from the back row.	
	Job Command: Jump	Specialty: None
1 Jump	Jump high into the air to attack from above.	
2 Lance	Steal enemies' HP and MP.	
3 Equip Lances	Gain the ability to wield lances. Additionally, the character's strength becomes equal to a dragoon's.	

NINJA



Fast and sneaky, ninjas are skilled at taking enemies by surprise. They can wield two weapons at once.

Job Command: Throw **Specialties:** Dual-Wield, First Strike

- 1 Smoke Use the resulting confusion of a smoke bomb to escape from enemies.
- 2 Image Create an illusory copy to absorb two hits.
- 3 First Strike Increase the chance of having preemptive strikes in random encounters.

SAMURAI



Samurai are skilled enough with their katana to stop and divert physical attacks.

Job Command: Zeninage **Specialty:** Shirahadori

- 1 Mineuchi Hit enemies with the dull side of the blade to stun them.
- 2 Zeninage Throw gil to harm all enemies.
- 3 Shirahadori Catch and stop some enemy attacks, completely preventing damage.

BERSERKER



In a constant rage, berserkers refuse all commands. However, the strength of their attacks is unmatched.

Job Command: None **Specialty:** Berserk

- 1 Berserk Always have berserk status in battle.
- 2 Equip Axes Gain the ability to wield axes. Additionally, the character's strength becomes equal to a berserker's.

RANGER



Ace archers, rangers lose no attack power when armed with a bow in the back row.

Job Command: Aim **Specialty:** None

- 1 Animals Call upon friendly wildlife for aid.
- 2 Aim Increases accuracy of attacks.
- 3 Equip Bows Gain the ability to use bows. Additionally, the character's strength and agility become equal to a ranger's.

MYSTIC KNIGHT



Mystic knights enchant blades with different spells. They can also create a barrier to weaken enemy magic attacks.

Job Command: Spellblade **Specialty:** Magic Shell

- 1 Magic Shell Automatically cast Shell when near KO.
- 2 Spellblade LV1 Enchant weapons with level 1 spells.
- 3 Spellblade LV2 Enchant weapons with level 2 spells.

WHITE MAGE



White mages use their powers to heal and buff allies.

Job Command: White **Specialty:** None

- 1 White LV1 Use level 1 white magic.
- 2 White LV2 Use level 2 white magic.
- 3 White LV3 Use level 3 white magic.

BLACK MAGE



From summoning raging fires to calling forth thunder from the skies, black mages have many destructive spells at their command.

Job Command: Black **Specialty:** None

- 1 Black LV1 Use level 1 black magic.
- 2 Black LV2 Use level 2 black magic.
- 3 Black LV3 Use level 3 black magic.

BLUE MAGE



With the ability to learn monsters' special skills, blue mages are unique casters.

Job Command: Blue **Specialty:** Learning

- 1 Check See an enemy's current HP and weak point.
- 2 Learning Get hit by an enemy's special attack to learn it as blue magic.
- 3 Blue Perform learned enemy skills.

TIME MAGE



Masters of time and space, time mages learn spells that bend the laws of nature to their will.

Job Command: Time **Specialty:** None

- 1 Time LV1 Use level 1 time magic.
- 2 Time LV2 Use level 2 time magic.
- 3 Time LV3 Use level 3 time magic.

RED MAGE



Able to learn both white and black magic spells, red mages can wield blades as well, making them versatile fighters.

Job Command: Red **Specialty:** None

- 1 Red LV1 Use level 1 white and black spells.
- 2 Red LV2 Use level 2 white and black spells.
- 3 Red LV3 Use level 3 white and black spells.

SUMMONER



Summoners are able to call magical beings and harness their powers.

Job Command: Summon **Specialty:** None

- 1 Summon LV1 Use level 1 summons.
- 2 Summon LV2 Use level 2 summons.
- 3 Summon LV3 Use level 3 summons.

BEASTMASTER



Often wielding whips, beastmasters can capture and control monsters.

Job Command: Catch (Release) **Specialty:** None

- 1 Calm Calm monsters so they are less likely to attack.
- 2 Control Manipulate monsters to attack other enemies.
- 3 Equip Whips Gain the ability to use whips; additionally, the character's strength and agility become equal to a beastmaster's.

CHEMIST



In addition to gaining twice the benefit of curative items, chemists can mix new, helpful medicines.

Job Command: Drink **Specialty:** Pharmacology

- 1 Pharmacology Gain twice the benefit when drinking potions or ethers.
- 2 Mix Combine two items to create a new one.
- 3 Drink Consume helpful potions meant for chemists.

GEOMANCER



Geomancers harness the power of nature to perform spectacular feats.

Job Command: Gaia **Specialties:** Light Step, Find Pits

- 1 Gaia Call upon the forces of nature to attack based on current location.
- 2 Light Step Avoid taking damage on floors covered in lava, etc.
- 3 Find Pits Backpedal before falling into holes in the floor.

BARD



With harps and songs, bards create tunes that inspire mysterious effects.

Job Command: Sing **Specialty:** None

- 1 Hide Avoid damage by hiding out of sight.
- 2 Equip Harps Become able to use harps; additionally, the character's agility and magic become equal to a bard's.
- 3 Sing Perform songs during battle to inspire different effects.

DANCER



In addition to stunning crowds with their smooth moves, dancers can equip special items no one else can.

Job Command: Dance **Specialty:** Learning

- 1 Flirt Charm enemies into not attacking.
- 2 Dance Perform one of a number of dances with different effects.
- 3 Equip Ribbons Become able to equip items meant for dancers.

MIME



Mimics can copy the actions of others down to the last detail.

Job Command: Mimic **Specialty:** None

- 1 Mimic Perform the same action as the previously acting ally.



SPELL LIST

This is only a selection of the wide variety of spells available in the game. During your quest, you will encounter many more spells, so make sure to keep an eye out for them!

White Magic		
Level 1	Cure	Restores HP.
	Libra	Determines target's HP, MP, and weakness.
	Poisona	Cures poison.
Level 2	Silence	Causes silence.
	Protect	Reduces physical damage received.
	Mini	Inflicts mini on target or restores state.
Level 3	Cura	Restores HP.
	Raise	Revives target.
	Confuse	Causes confusion.
Black Magic		
Level 1	Fire	Deals fire damage (minimal).
	Blizzard	Deals ice damage (minimal).
	Thunder	Deals lightning damage (minimal).
Level 2	Poison	Causes poison.
	Sleep	Causes sleep.
	Toad	Inflicts toad on target or restores state.
Level 3	Fira	Deals fire damage.
	Blizzara	Deals ice damage.
	Thundara	Deals lightning damage.

Time Magic		
Level 1	Speed	Hastens the pace of the battle.
	Slow	Slows the passing of time for one enemy.
	Regen	Gradually restores HP.
Level 2	Mute	Silences all allies and enemies.
	Haste	Hastens the passing of time for one ally.
	Float	Levitates target.
Level 3	Gravity	Halves target's HP.
	Stop	Causes time to stop, halting target's actions.
	Teleport	Warps party out of dungeon or out of battle.
Summon Magic		
Level 1	Chocobo	Calls a chocobo to kick an enemy.
	Sylph	Summons a wind that harms enemies and recovers the HP of allies.
	Remora	Stops enemies.
Level 2	Shiva	Attacks enemies with an icy blizzard.
	Ramuh	Strikes enemies with strong bolts of lightning.
	Ifrit	Burns enemies with the flames of hell.
Level 3	Titan	Triggers an earthquake that affects all enemies.
	Golem	Absorbs damage from physical attacks.
	Catoblepas	Turns enemies to stone.
Blue Magic		
Level 5	Death	Casts Death upon enemies whose levels are multiples of 5.
	Flash	Inflicts enemies with darkness.
	Transfusion	Sacrifices caster to completely restore an ally's HP and MP.
	Vampire	Steals HP from an enemy.
	Self-Destruct	Caster explodes, damaging an enemy.
	Doom	Curses one enemy to die in 30 seconds.